

[Print this document](#)

Nanotech Ready to Rock the Radio Industry

10/22/2008

Is radio the next hot industry for nanotechnology?

With major university programs announcing breakthroughs in nano-scale radio devices, something is afoot. But why are researchers focusing so much attention on radio? Because when it comes to marketable products, nano has been big on promises, but small on delivering, according to Dr. Peter Burke, Ph.D., associate professor of electrical engineering and computer science at the University of California, Irvine.

"In electronics there has been a shortage of demonstrations," says Burke. "We have had many 'proposed' real-world applications, but not enough demonstrations."

Burke notes that announcements touting denser memory or faster CPUs require low-cost manufacturing which hasn't arrived yet for nanotechnology, whereas his goal was to show a real-world application.

In October 2007, Burke and his team announced the world's first working radio system that could receive radio waves wirelessly and convert them to sound signals through a nano-sized detector. In this age of micro computer chips, the announcement was still a newsworthy event.

The "carbon nanotube radio" device is thousands of times smaller than the diameter of a human hair. Burke's demonstration had the detector integrated into a complete radio system and used it to transmit classical music wirelessly from an iPod to a speaker several feet away from the music player.

While carbon nanotubes are still a very young technology, they detect radio waves by using the same principle as an old standby of AM, the crystal diode radio.

"The only difference is that instead of the crystal we're using nanotubes," said Burke.

"There's no limit to the frequency it would work at, and we actually used a one gigahertz carrier wave that we generated in the lab because we wanted our own little radio station."

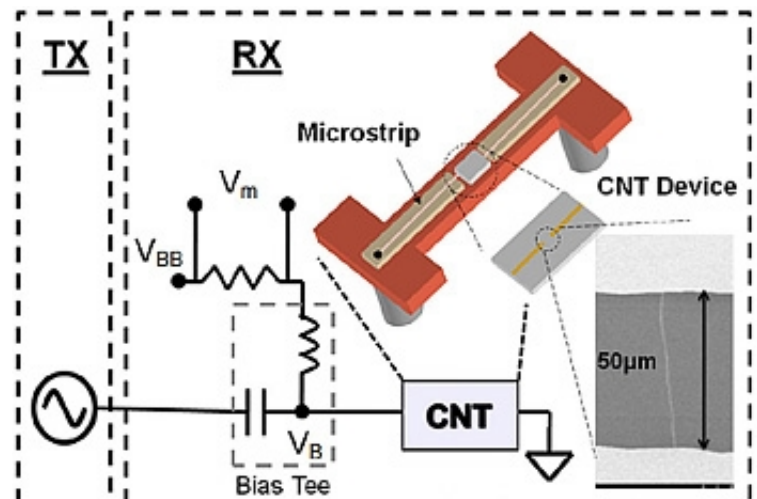

(click thumbnail)
Carbon Nanotube Diagram

Burke is the first to admit that his wasn't the first nano-sized radio wave detector demonstration, but he says the project broke new ground by creating a complete, nano-sized radio system.

Moreover, the study shattered doubts about the feasibility of manufacturing nano-scale radio component, ones that could lead to a "truly integrated nano-scale wireless communications system."

In fact, just such a system was recently announced by John Rogers, a professor of Materials Science and Engineering at the University of Illinois.

Rogers developed a nanotube-transistor radio system based on a heterodyne receiver design consisting of four capacitively coupled stages: an active resonant antenna, two radio-frequency amplifiers and an audio amplifier. Headphones were plugged directly into the output of a nanotube transistor. The design incorporated seven nanotube transistors into each radio. During the demonstration, researchers tuned to WBAL(AM) at 1090 kHz in Baltimore and heard a traffic report.

Making the tiniest radio isn't the ultimate goal for Rogers. Instead, the nanotube radio represents a milestone for proving that the technology is commercially competitive.

In benchmarking studies against silicon, measurements indicated significant advantages in comparably scaled devices. The ongoing research in nanotechnology has produced evidence that carbon nanotube transistors can be used for manufacturing low-power, high-speed transistors.

Not surprisingly, such potential is receiving support from industrial sectors and the U.S. government. Roger's project was done in collaboration with radio frequency electronics engineers at Northrop Grumman Electronics Systems in Linthicum, Md. The National Science Foundation and U.S. Department of Energy provided funding.

The interest is justified, says Burke.

"The noise, linearity, and fidelity that are important for radio communications can actually be improved with this technology," he said.

"It's still speculative but there are good physics reasons. The current flows in only one direction because the wire is so tiny. It can only go forward or back, but not left, right, up or down. In the Illinois work there are a lot of wires in parallel to get enough signal, but each electron flows through one tube at a time. Of course, no two electrons can be in the same place at the same time so the noise and current that flows is actually correlated and the randomness is somehow reduced because of this principle."

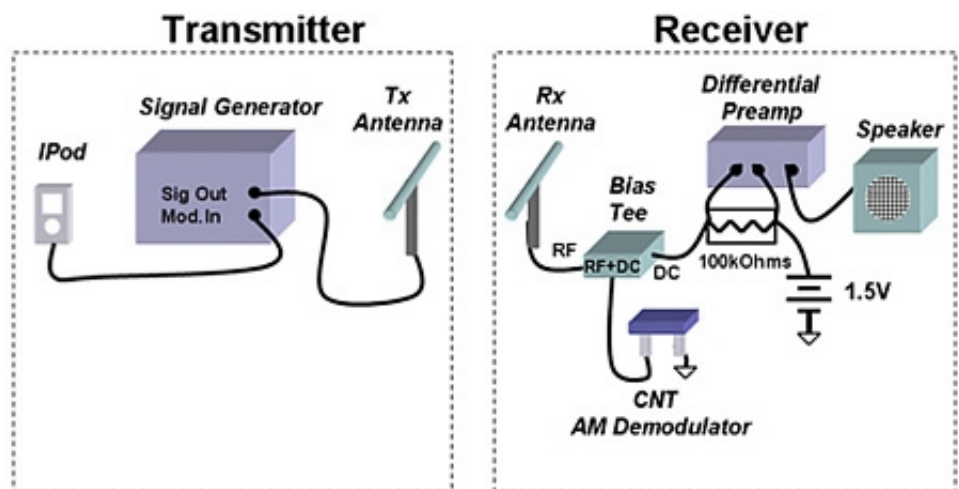

(click thumbnail)

Carbon Nanotube Radio Setup. Graphics courtesy Dr. Peter Burke

With such advantages, the next question would be how long until we see products.

Burke notes that major corporations and research institutions are engaged in a race to bring such products to market, and he too, is on a fast track to commercialization.

In 2006, he launched RF Nano, with \$1.5 million in venture capital, plus funding from the U.S. Army and the National Science Foundation, for carbon nanotube antennas, FETs, and integrated nanotube systems. Burke says he has received interest from radio industry manufacturers and others in related fields, but there are still some manufacturing issues to address.

Rogers is a little more optimistic. He announced that nanotube devices and circuits are now possible, thanks to a novel growth technique developed with colleagues at the University of Illinois, Lehigh and Purdue universities.

The breakthrough produces linear, horizontally aligned arrays of hundreds of thousands of carbon nanotubes, and they function collectively. Moreover, the process produces a thin-film semiconductor material so the arrays can be integrated into electronic devices and circuits using conventional chip-processing techniques.

The analog radio frequency market offers great potential for Rogers, and a scenario where products filter down from the military is likely, according to predictions from Dr. John Przybysz, Ph.D., a University of Illinois alumnus and a senior consulting engineer at Northrop Grumman.

Przybysz says nanotube technology is a breakthrough in power requirements for military sensor systems because they perform equally with other microwave transistors but use much less power than today's semiconductor devices. For example, batteries that expired after two days usage could now last up to two weeks due to the lower power consumption of nanotube transistors.

Ultimately, whether it's a military application, or commercial, nanotechnology is viewing radio as an industry with high potential for short-term applications.

Looking a little farther out, Burke believes that the potential isn't limited to traditional radio communications.

"Our radio receiver is atomic scale but the battery and antenna are large," says Burke. "If we eliminated the battery and reduced the antenna we could insert it into an individual cell so we communicate information back and forth between the cell and the outside world. It's more futuristic, but it's also more exciting."

Comment on this or any article to radioworld@nbmedia.com. Contact the author at eritchie@pacbell.net.